

What can quantum optics say about computational complexity theory?

Saleh Rahimi-Keshari, Austin P. Lund, and Timothy C. Ralph

Centre for Quantum Computation and Communication Technology,
School of Mathematics and Physics, University of Queensland, St Lucia, Queensland 4072, Australia

Boson Sampling is an intermediate model of quantum computation that seeks to generate random samples from a probability distribution of photon counting events at the output of an M -mode linear-optical network consisting of passive optical elements, for an input with N of the modes containing single-photons and the rest in the vacuum states [1]. There is great interest in this particular computational problem as this task, despite its simple physical implementation, is strongly believed to be a problem that cannot be efficiently simulated classically.

A key observation that leads to the proof of the classical hardness of Boson Sampling is that the photon counting probabilities are proportional to the modulus-squared of permanents of complex matrices [1]. The permanent of a matrix is a quantity which is calculated in a similar manner to a matrix determinant but without the alternating of addition and subtraction and instead only adding terms. Computing permanents is believed difficult ($\#P$ -hard in complexity theory), and it is in a class that contains the hierarchy of complexity classes (the polynomial hierarchy) [3, 4]. It was shown that, as approximating those probabilities to within a multiplicative constant is also a $\#P$ -hard problem, Boson Sampling cannot be simulated classically, unless the polynomial hierarchy collapses to the third level; a situation believed to be highly unlikely.

By using tools of quantum optics we present new results that are of interest from both quantum theory and the computational complexity theory point of view [2]. We consider the problem of sampling from the photon-counting probability distribution at the output of a linear-optical network for input Gaussian states, which is referred to as *Gaussian Boson Sampling*; see Fig. 1. We first present a general formula for the probabilities of detecting single-photons at the output of the network. Then by using this formula we show that probabilities of single-photon counting for input thermal states are proportional to permanents of positive-semidefinite Hermitian matrices. However, as thermal states are a statistical mixture of coherent states, we show that sampling from the output probability distribution can be efficiently simulated on a classical computer. Thus, by using Stockmeyer's approximate counting algorithm [1, 5], one can approximate permanents of positive-semidefinite Hermitian matrices in the complexity class $BPP^{\#P}$, which is contained in the third level of the polynomial hierarchy and hence believed to be less computationally complex than $\#P$ -hard. Similarly, using the same argument we show that Boson Sampling with any classical states, which have a positive semi-definite P function, can be simulated on a classical computer, and the output probabili-

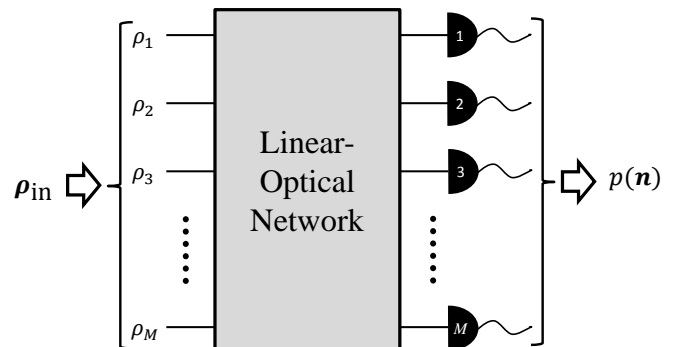

FIG. 1: In Gaussian Boson Sampling problem for given a product Gaussian input state, $\rho_{\text{in}} = \otimes_{s=1}^M \rho_s$, and a unitary matrix describing the network, one samples from the output probability distribution $p(\mathbf{n})$.

ties can be approximated in $BPP^{\#P}$.

In addition, we consider squeezed-vacuum states as input to a linear-optical network. We show that the probabilities of detecting single-photons at the output proportional to modulus-squared of a quantity O_N , which is obtained by summing up $(N-1)!!$ complex terms with N being the number of the detected single-photons. It was recently shown that a specific case of this problem is equivalent to a randomized version of the Boson Sampling problem that cannot be efficiently simulated using a classical computer [6]. This implies that, following the results from [1, 5], at least for this specific problem even approximating $|O_N|^2$ to within a multiplicative error is $\#P$ -hard. However, this would be surprising if this problem was the only case of the general problem of Boson Sampling with squeezed-vacuum states, for which approximating $|O_N|^2$ is a $\#P$ -hard problem. We believe our results show that the consideration of problems in quantum optics can help to classify and identify new problems in complexity theory.

-
- [1] S. Aaronson and A. Arkhipov, *Theory of Computing* **9**, 143 (2013).
 - [2] S. Rahimi-Keshari, A. P. Lund, T. C. Ralph, arXiv:1408.3712 (2014).
 - [3] L. Valiant, *Theor. Comput. Sci.* **8**, 189 (1979).
 - [4] S. Aaronson, *Proc. Roy. Soc. London A* **467**, 3393 (2011).
 - [5] L. J. Stockmeyer. The complexity of approximate counting. In *Proc. ACM STOC*, pages 118-126, (1983).
 - [6] A. P. Lund, A. Laing, S. Rahimi-Keshari, T. Rudolph, J. L. O'Brien, and T. C. Ralph, *Phys. Rev. Lett.* **113**, 100502 (2014).